

Data Calculation

Permissible Rotational Speed

[Ball screw Shaft Critical Speed]

As the rotational speed of the ball screw shaft increases, it approaches the natural frequency of the screw shaft, which can cause resonance and lead to operational failure. To ensure safe operation below this resonance point, the maximum permissible speed is defined as the critical speed.

[Allowable Speed Calculation Formula]

$$N_1 = \frac{60 \cdot \lambda_1^2}{2\pi \cdot L_a^2} \times \sqrt{\frac{E \cdot 10^3 \cdot I}{\gamma \cdot A}} \times S = \lambda_2 \times \frac{dr^4}{L_a^2} \times 10^7$$

L_a (mm)	: Distance between mounting surfaces	Coefficient corresponding to installation method
A (mm ²)	: Shaft cross-sectional area	Installation Method λ_1
E (N/mm ²)	: Elastic modulus (=2.06x10 ¹¹)	Fixed-Free 1.875 3.4
dr (mm)	: Screw shaft thread inner diameter	Support - Support 3.142 9.7
I (mm ⁴)	: Secondary axial moment of section	Fixed-Support 3.927 15.1
S	: Safety factor (usually 0.8)	Fixed-Fixed 4.73 21.9
γ (kg/mm ³)	: Density (specific gravity) (=7.85x10 ⁷)	

$$* I = \frac{\pi}{64} \cdot d \cdot r^4 \quad * A = \frac{\pi}{4} \cdot d \cdot r^2$$

Mean Load

[Mean Load Calculation]

The loads applied to a linear guide system vary depending on various operating conditions. All load conditions must be taken into account to accurately calculate the load capacity required by the linear guide system.

[Mean Load Calculation Formula]

P_m (N)	Average Load
P_c (N)	Changing Load
L (mm)	Total Length Of Trip
L_n (mm)	The Length Of The Stroke Carrying P_n

$$P_m = \sqrt[3]{\frac{1}{L} \cdot \sum_{m=1}^n (P_n^3 \cdot L_n)}$$

[Stepped Load Variation]

$$P_m = \sqrt{\frac{1}{L} (P_1 \cdot L_1 + P_2 \cdot L_2 + \dots + P_n \cdot L_n)} \quad (1)$$

P_m (N)	Average Load
P_c (N)	Changing Load
L (mm)	Total Length Of Trip
L' (mm)	Stroke Length Carrying P_n

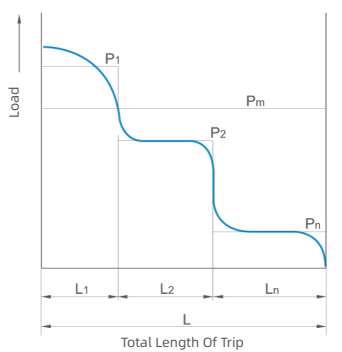

[Monotonic Load Variation]

$$P_m \approx \frac{1}{3} (P_{min} + 2 \cdot P_{max}) \quad (2)$$

P_{min} (N)	Minimum Load
P_{max} (N)	Maximum Load

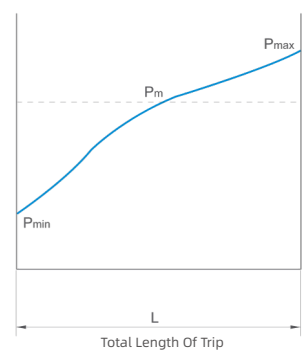

Ball screw Service Life

[Service Life of Ball Screw]

The calculated service life is generally defined as the life limited by fatigue flaking. The fatigue life of a ball screw can be estimated using the basic dynamic load rating (Ca).

[Basic Dynamic Load Rating (Ca)]

The basic dynamic load rating refers to the axial load under which 90% of a group of identical ball screws can operate for 1 million revolutions (10⁶ rev) without flaking due to rolling fatigue.

[Fatigue Life]

$$L_{10} = \left(\frac{Ca}{f_w \times F_a} \right)^3 \times 10^6$$

$$L_t = \frac{L_{10}}{60N}$$

$$L_S = \frac{L \times L_{10}}{10^6}$$

L_{10} : Rated Fatigue Life [rev]
 L_t : Service Life Time [h]
 L_s : Travel Life Distance [km]
 Ca : Basic Dynamic Load Rating [N]
 n : Rotational Speed [min⁻¹]
 l : Lead [mm]
 f_w : Load Factor
 $f_w = 1.0-1.2$: Little to no vibration or shock
 $f_w = 1.2-1.5$: Moderate vibration or shock
 $f_w = 1.5-3.0$: Severe vibration or shock

Application

Linear Guides: CNC Machines, Injection Molding, Medical, Display, Semiconductor, Automation, Lithium Battery



Ball Screws: Powder Presses, Machine Tools, Injection Molding Machines, Industrial Robots



Single-Axis Modules: Loader Vehicles, Injection Molding Machines, Battery Swap Stations



For more information, please contact our local offices.

International Offices

- Germany-Stuttgart**
Tel: +49 (0) 7144 8990
sales.de@inovance.eu
- Spain-Barcelona**
Tel: +34 93 504 94 48
sales.es@inovance.eu
- Italy-Milano**
Tel: +39 (0) 2268 22318
sales.it@inovance.eu
- France-Bordeaux**
Tel: +33 (0) 5594 01050
sales.kr@inovance.eu
- India**
Head Office Chennai Tel: +91 (0) 44 4380 0201
Ahmedabad Tel: +91 (0) 79 4003 4274
Mumbai Tel: +91 (0) 22 4971 5883
Noida Tel: +91 (0) 11 4165 4524
Hyderabad Tel: +91 (0) 40 4951 6431
Surat Tel: +91 (0) 93846 65692
- Hong Kong SAR**
International export office
Tel: +852 2751 6080
info@inovance.eu
For other country distributors, contact the Hong Kong office.
Inovance Technology Companies
Shenzhen Inovance Technology Co. Ltd.
Suzhou Inovance Technology Co. Ltd.
- Sales Network**
Coimbatore, Bengaluru, Pune, Indore, Vadodara, Visakhapatnam, Kanpur, Jaipur, Chandigarh, Kolkata

INOVANCE
www.inovance.eu

INOVANCE

INOVANCE PRECISION MACHINERY



Model Selection

Linear Guide

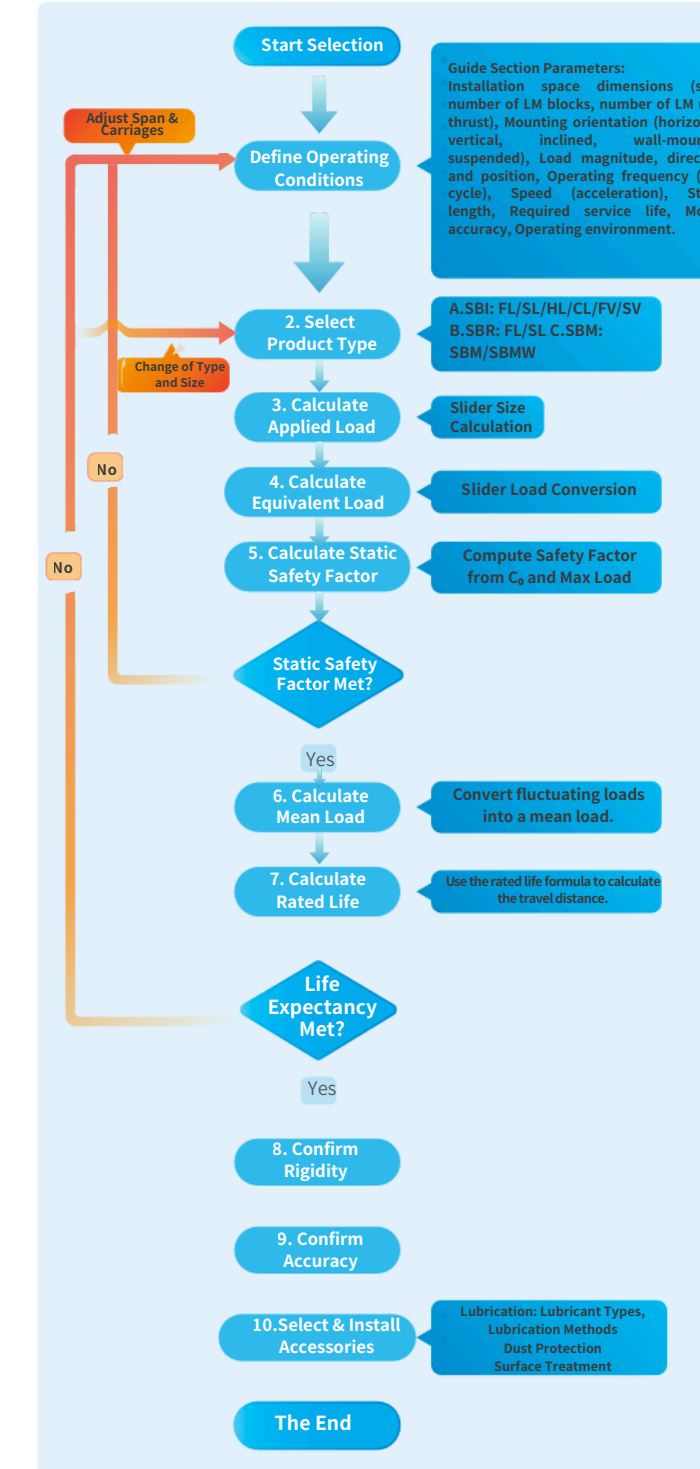

Ball Screw

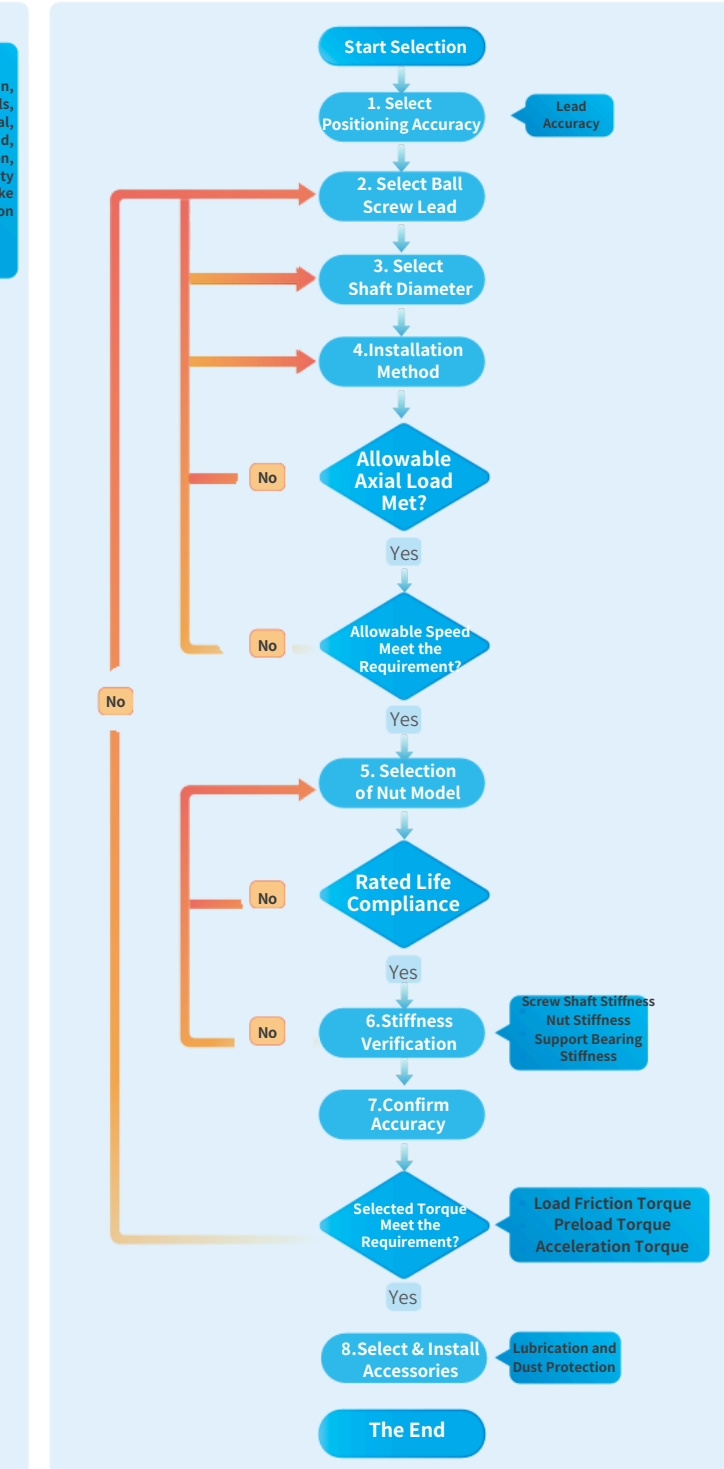

Single-Axis Actuator

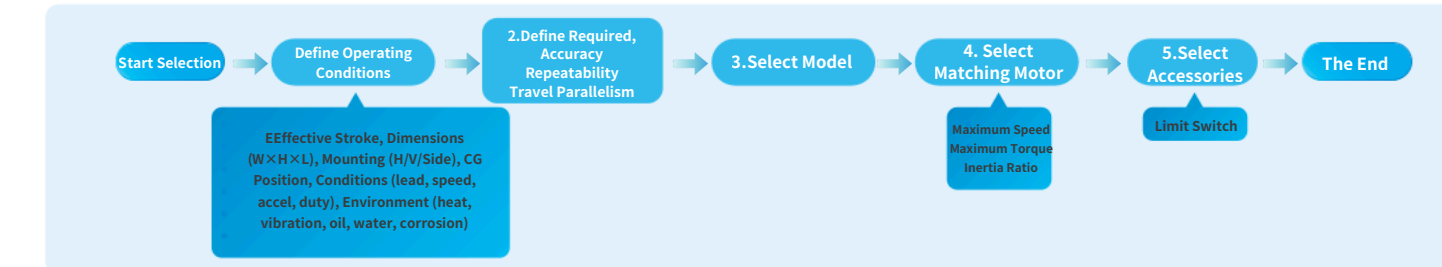



In May 2023, Inovance officially completed the acquisition of Korea-based SBC Linear Co., Ltd. (SBC). This acquisition adds a new product line of precision linear guides, enhancing Inovance's multi-product portfolio capabilities and supporting its goal of becoming a leading supplier of precision mechanical transmission products and solutions.

PRODUCT RANGE

Linear Guide Systems, Rolled Ball Screws, Robot Carrier Rails

ADVANTAGE

Design, Materials Engineering, Testing and Analysis with Global Technical Competitiveness

INOVANCE

Fully Acquired in 2023

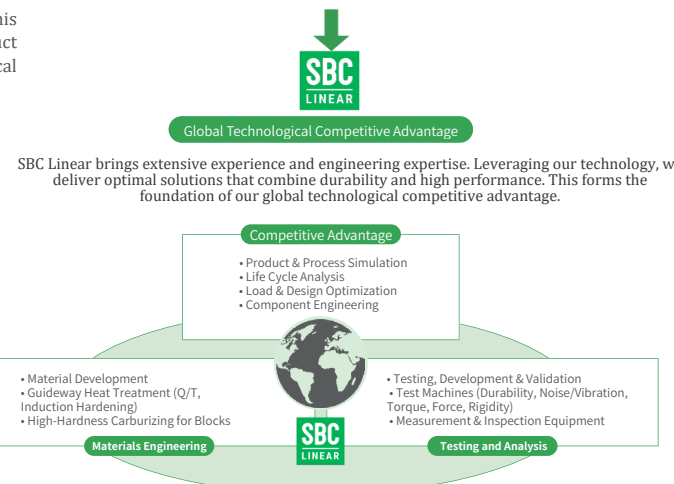

In June 2016, Lian formed a capital partnership with Inovance. Backed by Inovance's R&D and market strengths, Lian has enhanced its competitiveness and grown into a recognized brand in electric injection molding machines, CNC tools, and SCARA robots.

PRODUCT RANGE

Ball Screws (BS/PBS), Rotary Ball Splines (RBS), Mechatronic Integrated Products (Single-Axis Robots / Electric Cylinders)

ADVANTAGE

Inheriting 30 years of precision ball screw design and manufacturing expertise from Japan's NTN. Key components use imported materials. Equipped with advanced international grinding, heat treatment, and inspection systems. Modern enterprise management system. Provides integrated electromechanical product solutions.

TECHNOLOGIES AND FACILITIES

Inherits 30 years of precision screw technology from Japan's NTN. Equipped with advanced imported grinding, heat treatment, and inspection systems. Complete capabilities in rail design, manufacturing, and testing. Leading in rail straightening, slider broaching, precision grinding, and preload adjustment.

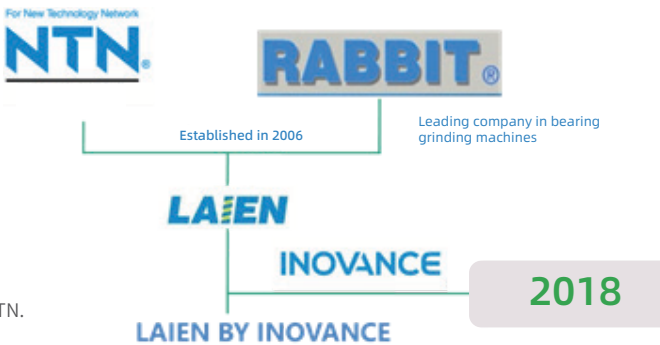
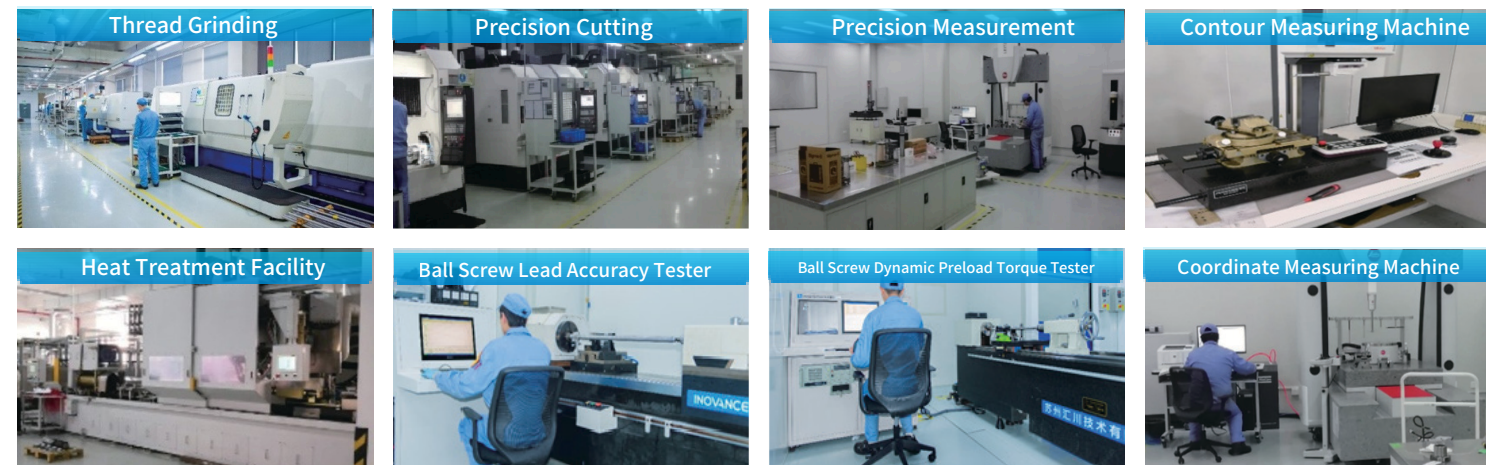

Linear Guide

SBI Ball-Type Series

Smooth motion, high rigidity, 8 models (15-65); for LCD, CNC, molding, lithium, semiconductor, auto equipment

- 4-row, 2-point arced contact
- DF Self-Aligning Structure
- Optimal Loop Design
- Multiple Sliders and Options

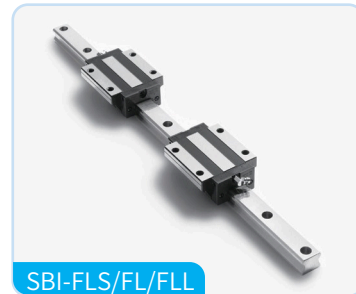

SBI-FLS/FL/FLL

Heavy Load Flange Type
15-65 / 8 Models

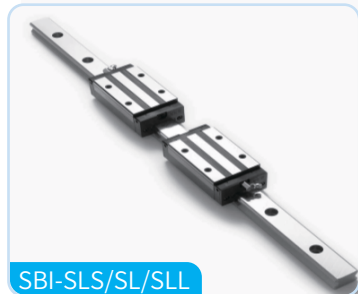

SBI-SLS/SL/SLL

Heavy Load Slim Type
15-65 / 8 Models

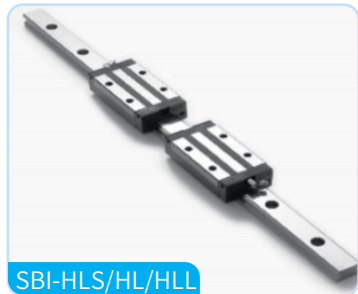

SBI-HLS/HL/HLL

Low Profile Slim Type
15-45 / 5 Models

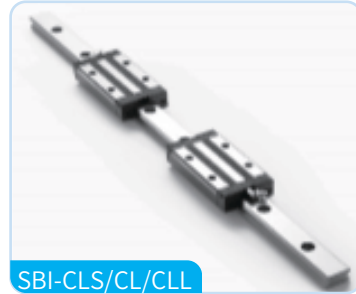

SBI-CLS/CL/CLL

Compact Slim Type
20-25 / 2 Models

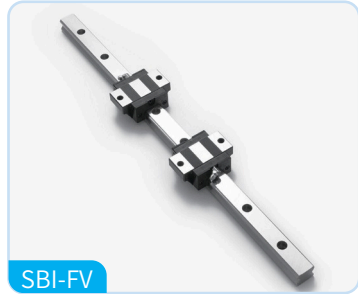

SBI-FV

Short Flange Type
15-35 / 3 Models

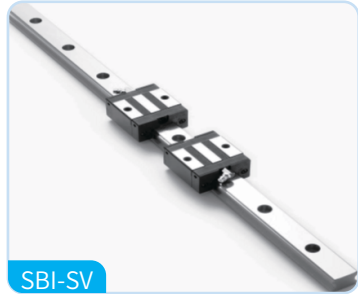

SBI-SV

Short Slim Type
15-35 / 3 Models

SBR Roller-Type Series

High rigidity, high load capacity, smooth operation; 4 models (30-55); commonly used in machine tool applications.

- Roller Contact Surface
- Optimal Loop Design
- Smooth Operation
- Logarithmically Distributed Optimized Rollers

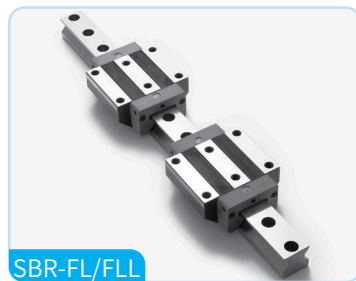

SBR-FL/FLL

Roller Flange Type
30-55 / 4 Models



SBR-SL/SLL

Roller Slim Type
30-55 / 4 Models

SMN/SMW Miniature Ball Bearing Series

"High load, high torque, smooth operation; 4 models (7-15); used in medical and semiconductor industries.

- Double-row Gothic groove
- Rolling Element Retention
- Low Noise & Lubrication
- Smooth Operation

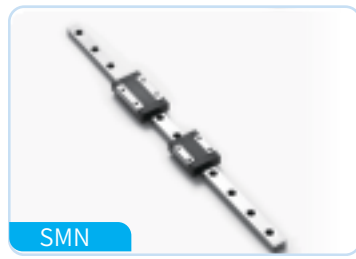

SMN

Standard/Long Type Miniature
7-15 / 4 Models

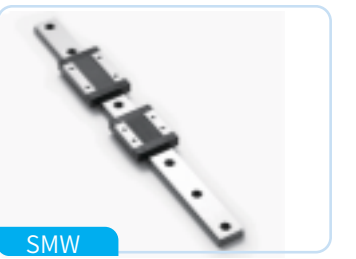

SMW

Wide/Wide-Long Type Miniature
9-15 / 3 Models

Ball Screw

Ball Screw for High-Load Drives

High load, high speed, excellent sealing, low noise; integrated solutions. Widely used in electric injection molding machines, metal forming, servo presses, semiconductors, and construction machinery.

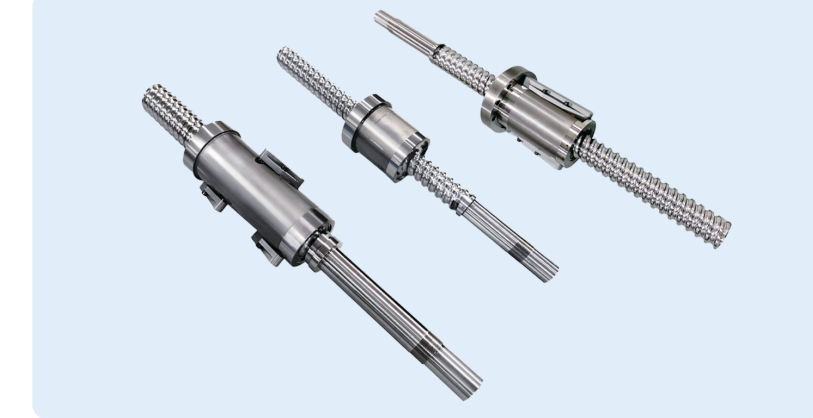

HSP Series

High-speed feed up to 800 mm/s with small lead; shaft diameter $\phi 50$ - $\phi 120$ mm, lead 10-50 mm.

HSL Series

High-speed feed up to 1600 mm/s with large lead; shaft diameter $\phi 50$ - $\phi 80$ mm, lead 32-50 mm.

PBS(K) Series

Available in a wide range of shaft diameters $\phi 50$ - $\phi 140$ mm and leads 14-70 mm.

RBS - Precision Ball Spline

Compact structure, low inertia, high speed, self-lubricating; commonly used in SCARA robots.

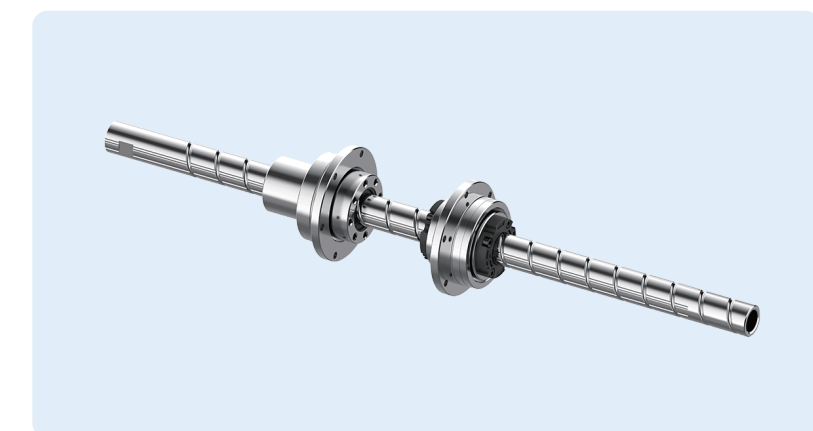

Shaft diameter $\phi 16$ - $\phi 25$ mm, lead 16-50 mm.

- High precision
- High Load Capacity
- Lightweight
- Reliable Rigidity
- Low noise

BS - High-Speed Precision Ball Screw

High precision, high speed, superior sealing, excellent accuracy retention; widely used in machine tool industry.



Shaft diameter $\phi 8$ - $\phi 80$ mm, lead 2-50 mm

Actuator

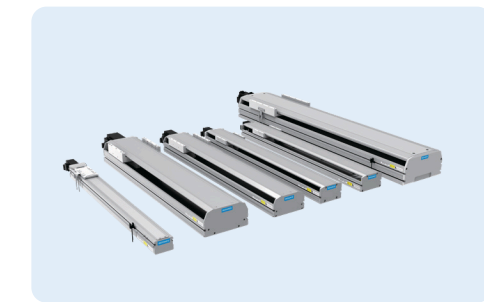

LS Series - Standard Ballscrew Type

- High precision and load capacity
- Max stroke 2400 mm, speed 2000 mm/s
- 8 models (sizes 12-27)
- Widely used in automation: handling, positioning, compensation, and path tracking

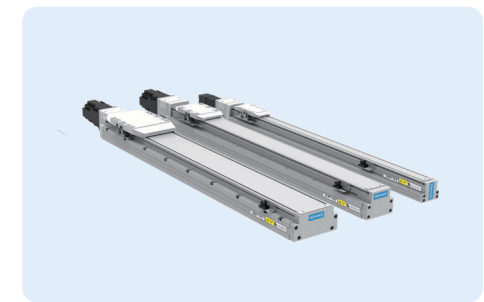

GS Series - Embedded Ballscrew Type

- High precision, high load, compact size, strong one-piece rigidity
- Max stroke 1200 mm, speed 1600 mm/s
- 4 models (sizes 4-12)
- Widely used as Z-axis in mobile, display, semiconductor, and food industries



KS Series - Steel Base Ballscrew Type

- U-shaped steel rail, high rigidity, equal load in four directions
- Max stroke 940 mm, speed 1480 mm/s
- 2 models (sizes 60-86)
- Ideal for handling, positioning, and compensation in 3C automation



LB Series - Standard Belt Slide Type

- Long stroke, high speed
- Max stroke 3050 mm, speed 2000 mm/s
- 4 models (sizes 11-22M)
- Widely used in automation for long-stroke, heavy-load handling

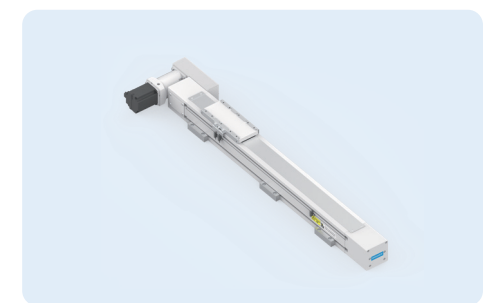

LEB Series - Euro Standard Belt Slide Type

- High load and speed, vertical-use capable
- Max stroke 5000 mm, speed 5000 mm/s
- 3 models (sizes 65-110)
- Ideal for long-stroke, high-speed automation handling



LSC Series - Clean Screw Slide Type

- Low particle generation, long lifespan
- Max stroke 1050 mm, speed 2000 mm/s
- 3 models (sizes 12-17)
- Used in dust-sensitive positioning for semiconductor, video, and display industries

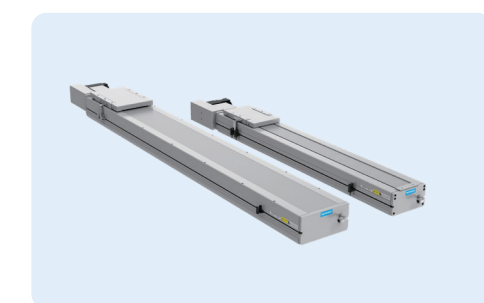

LBC Series - Clean Belt Type

- Low particle generation, long lifespan
- Max stroke 4050 mm, speed 2000 mm/s
- 2 models (sizes 14-17)
- Used in dust-sensitive handling for semiconductor, food, and display industries

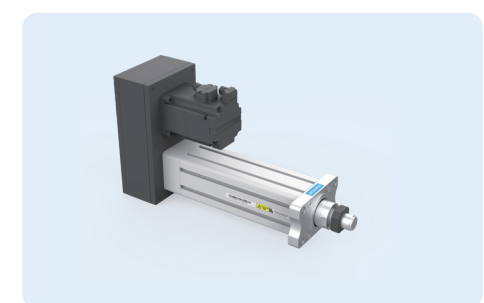

LY Series - Ball Screw Actuator Type

- Max stroke 1000 mm, thrust up to 8 kN
- 3 models (sizes 50-75)
- Commonly used in machine tools, lithium battery pressing, etc

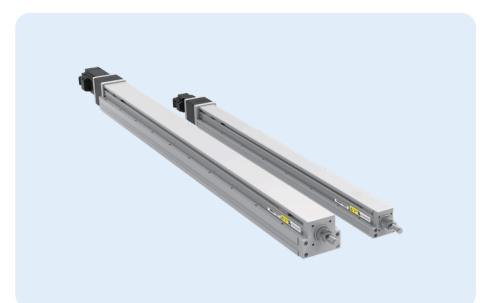

GY Series - Rail-Embedded Rod Type

- Max stroke 800 mm, speed 1000 mm/s
- 2 models (sizes 5-8)
- Mainly used as final two axes in mobile, display, and semiconductor industries